

Chapter 3

Creating Solids & Surfaces from 2D Objects

In this chapter you learn how to create solids and surfaces from 2D objects, draw helixes and 3D polylines, as well as create and modify 3D extrudes, sweeps, revolves, and lofts.

- Complex 3D Geometry
- Extruded Solids and Surfaces
- Swept Solids and Surfaces
- Revolved Solids and Surfaces
- Lofted Solids and Surfaces

This Page is Intentionally Left Blank





3.1 Complex 3D Geometry

Instead of spending many hours creating objects with complex curves or intricate shapes using primitives and Boolean operations, use the easier method of creating solid objects from 2D objects. These objects, such as the door handle and pulleys shown in Figure 3-1, can be created from polylines, polygons, circles, ellipses, splines, and regions.



Figure 3-1

Creating Surfaces and Solids

You can create complex 3D geometry using one of four primary commands:  (Extrude),  (Revolve),  (Sweep) and  (Loft). In each case, you can create a solid or a surface depending on the type of defining geometry you use. These commands use profiles and paths.

A profile is a 2D object that defines the cross-section shape of the 3D object. If the profile is closed, the result is a solid; if the profile is open, the result is a surface, as shown in Figure 3-2.

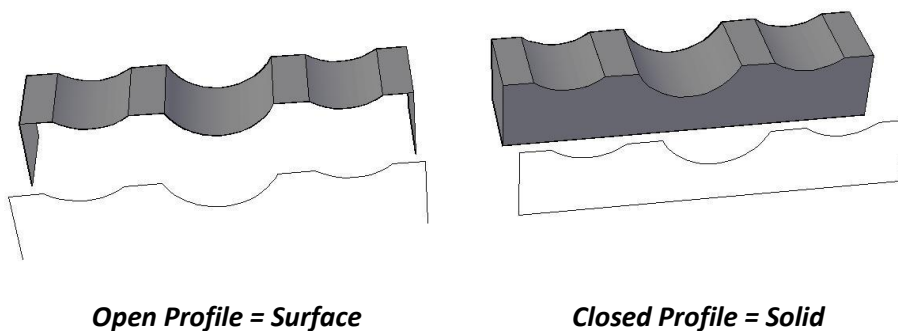

Figure 3-2

A path is the guide that the profile follows as it is being made into a solid or surface. Paths can be 2D or 3D objects.

- By default, profiles and paths are deleted when a solid or surface is created. This can be modified in the Options dialog on the *3D Modelling* tab, in the *3D Objects* area, by selecting an option in the Deletion control while creating 3D objects drop-down list.
- Complex solids (but not surfaces) can be modified using **Union**, **Intersect**, and **Subtract**.

3.2 Extruded Solids and Surfaces

The **Extrude** command creates a solid or surface object that has a constant cross-section shape, as shown in Figure 3-3. Many different objects can be created with extrusions, from simple gears and plates to building concepts based on complex floor plans.

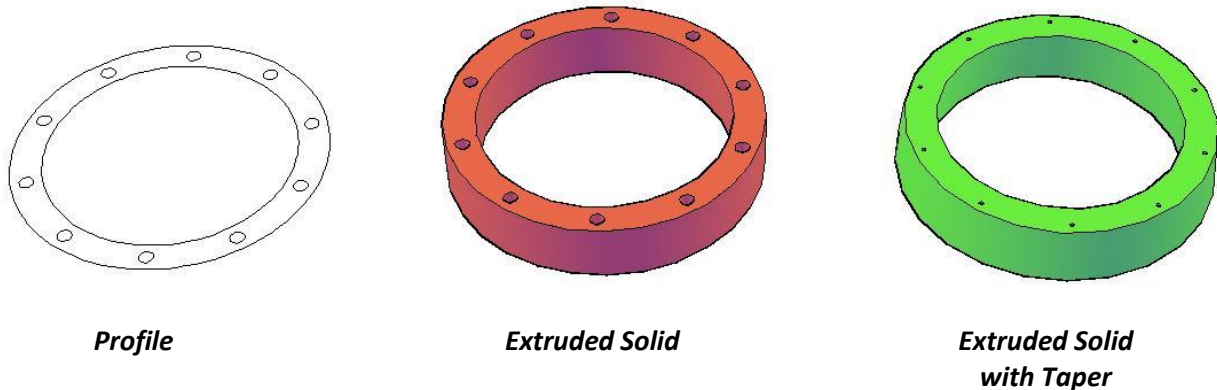



Figure 3-3

- The extruded solid or surface is created on the current layer

	Extrude
Ribbon :	<i>Home tab> Modelling panel or Solid tab>Solid panel</i>
Command prompt:	extrude

How To: Extrude an Object

1. Click  (Extrude).
 2. Select the object(s) to be extruded and press <Enter>.
 3. Specify the height of the extrusion by selecting a point in space or typing a distance.
- A line can be extruded to create a flat surface. An arc can be extruded to create a curved surface. Open 2D polylines or 2D splines become surfaces, while closed polylines, splines, and circles become solids.
 - You can select an edge or face of an existing 3D object to use as the profile or curve on the extrusion. Hold down <Ctrl> to select the edge or face.
 - You can extrude multiple objects in different direction and can also extrude non-planar profiles, such as splines.
 - Use the **Mode** option to set the extrusion to be created as a surface or solid.

Extrude Options

Direction	Enables you to specify a start point and end point for the extrusion. Typically, the start point is a point on the profile and the end point is some other point in 3D space. Use object snaps or typed in coordinates for the second point.
Path	Extrudes the profile along a previously drawn path. The path can consist of lines, circles, arcs, ellipses, elliptical arcs, 2D or 3D polylines, 2D or 3D splines, helixes, and edges of solids and surfaces.
Taper angle	Enables you to specify a tapered angle for the extrusion. A positive taper angles into the object, while a negative taper angles away from the object. The tapered angle cannot cause the solid to intersect itself. A preview of the taper is displayed.
Expression	New in 2011 Set the height using an equation or formula

Presspull

The Presspull command creates a region from overlapping 2D objects and extrudes them all in one step. If you push a region away from the existing solid, it removes that portion of the solid. For example, draw a rectangle on a face, start the PressPull command, move the cursor over the region, and push it away from the solid. It subtracts that area from the solid, as shown in Figure 3-4.

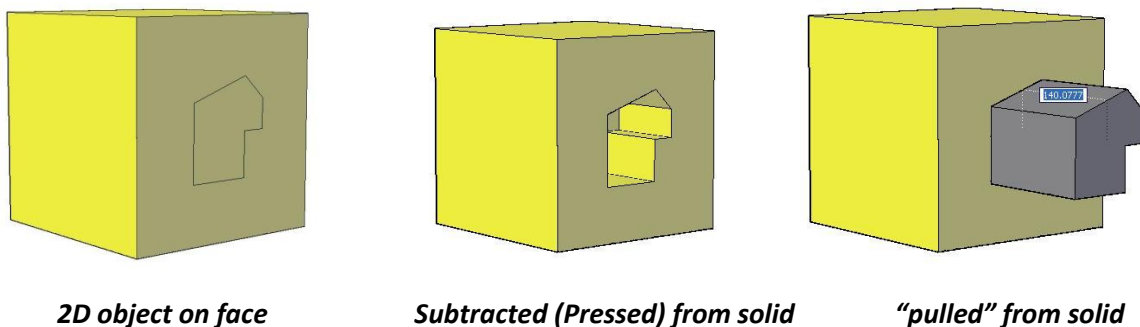



Figure 3-4

	Presspull
Ribbon :	<i>Home tab>Modelling panel or Solid tab>Solid panel</i>
Command prompt:	<i>presspull or <ctrl> +<shift>+E</i>

How To: use the Presspull Command

1. Click  (Presspull) or hold down <Ctrl>+<shift>+E.
2. Move your cursor inside a closed boundary area. You see the potential boundaries highlight as you move your cursor around. The objects do not need to be closed, but the boundary must be closed.
3. Click and "pull" the object up or "press" the object down to create the extruded solid.
4. AutoCAD automatically creates a region and extrudes it to the distance specified.

Modifying Extrusions

When you are working with extruded solids or surfaces, you can manipulate the vertices of the profile, as well as change the height of the extrusion with the arrow grip. It does not matter if the profile object is open (surface) or closed (solid) for the modification process. The height and taper angle can also be modified in Properties, as shown in Figure 3-5.

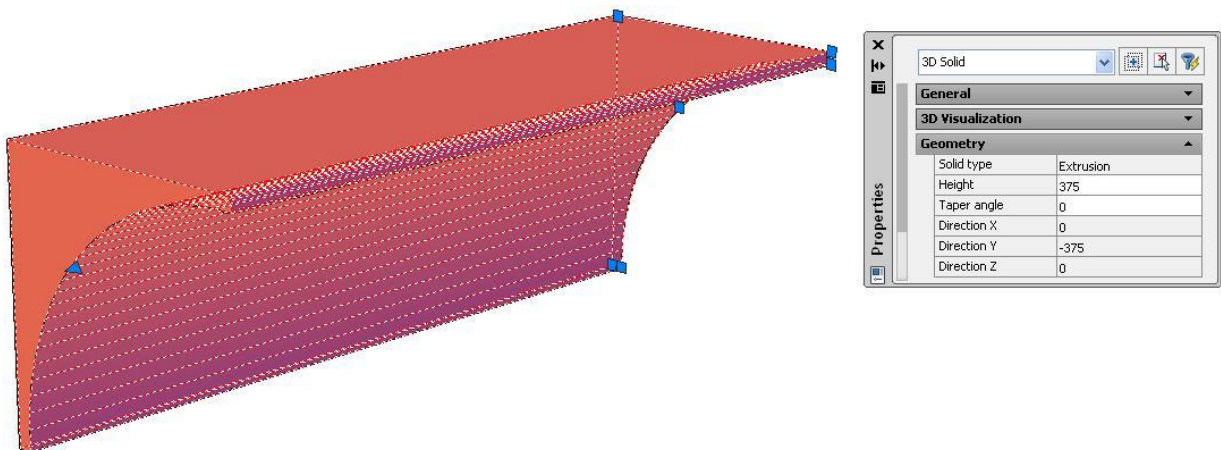

Figure 3-5

- If the extrusion uses a path, you can modify the profile and the path with grips.
- If an extrusion is tapered, you can change the profile and the height, but not the tapered angle. The tapered angle can be modified in Properties.
- If the extrusion was created using the **Direction** option, only the height and the profile can be modified, not the direction.
- Solids created by **Presspull** are considered extrusions. However, you cannot modify the vertices of the profile because they are created from a region.
- If you do not know what type of solid or surface you are working with, select it and look in Properties. The type is listed in the *Geometry* section.

Practice Exercise 3-1: Creating an Extruded Solid

In this practice you use **Extrude**, **Intersect**, and **Subtract** to create a solid, as shown in Figure 3-6. Estimated time for completion: 5 minutes.

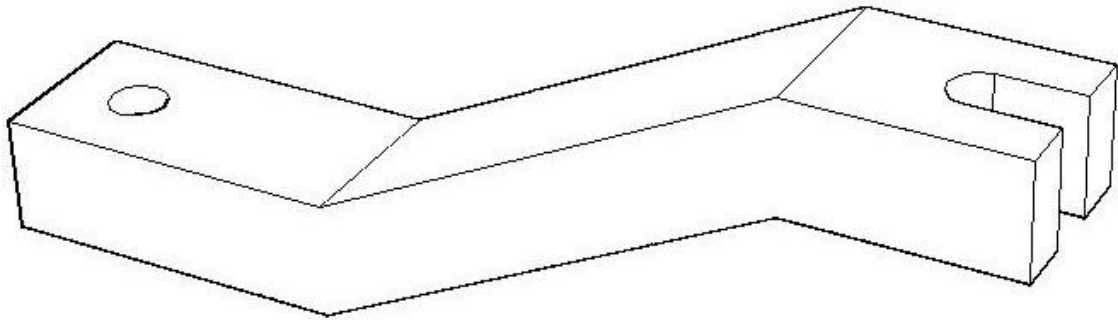



Figure 3-6

1. Open the drawing **Bar2-11.dwg**
2. Switch to the **SE Isometric** view.
3. Click  (Extrude). Extrude the top view, as shown in Figure 3-7, to a height of **3**.

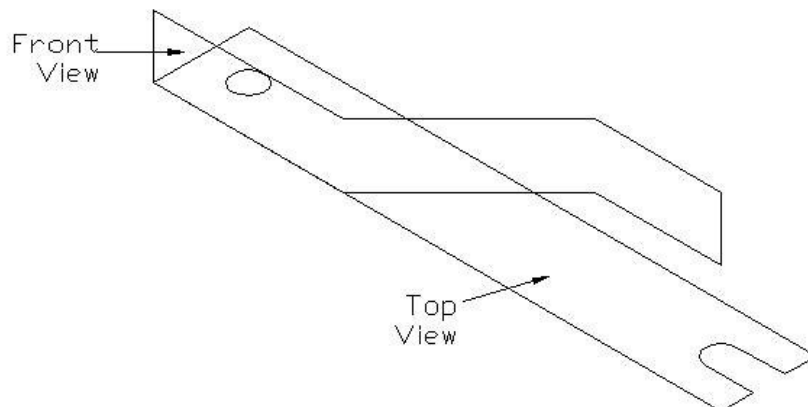



Figure 3-7

4. Click  (Extrude) again. Extrude the front view (the profile standing up in the figure above) to a height of **3**.
5. Intersect the two extruded objects.
6. Extrude the small circle at the end of the part to a point above the other extrusions.
7. Subtract the resulting cylinder from the bar to create a hole.
8. Change the *visual style* to **Realistic**.
9. Save and close the drawing.

Practice Exercise 3-2: Extruding along a Path

In this practice you extrude along a path to create a solid, and then subtract the new solid from an existing solid to create a groove, as shown in Figure 3-8. Estimated time for completion: 5 minutes.

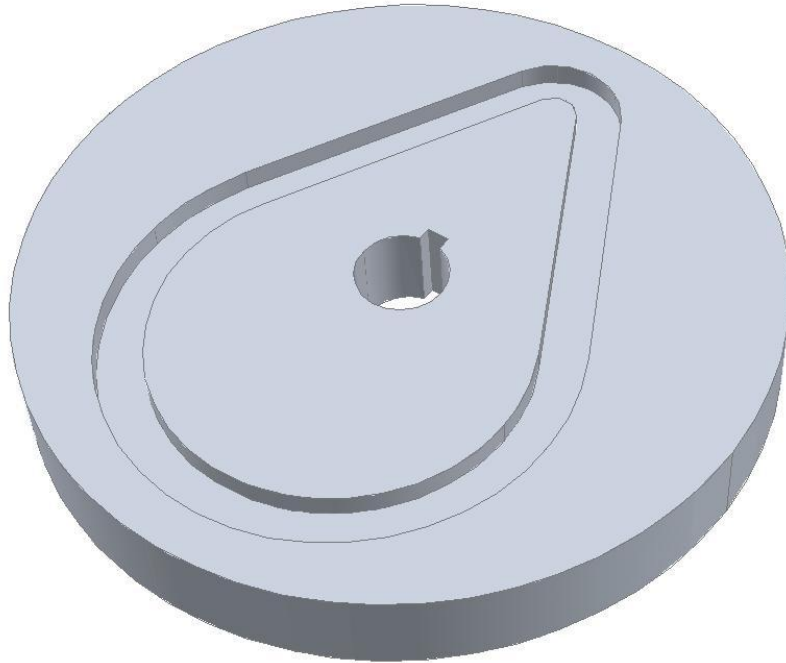



Figure 3-8

1. Open the drawing **Cam-11.dwg**.
2. Rotate the view to familiarize yourself with the objects.
3. Click  (Extrude) and select the blue rectangle. At the "Specify height" prompt, use the **Path** option and select the grey polyline as the path.
4. Change the *visual style* to **Realistic** to view the results.
5. Subtract the extrusion from the disk.
6. Erase the grey polyline that served as the path.
7. Save and close the drawing.

3.3 Swept Solids and Surfaces

The **Sweep** command is similar to the **Extrude** command, except regarding the path. With Extrude, the profile object must be in the correct relationship with the path. Sweep is much simpler to use, as it does not require the profile to be aligned with the path. Sweeps can be used for roof lines, piping (as shown in Figure 3-9), ribs, and slot features.

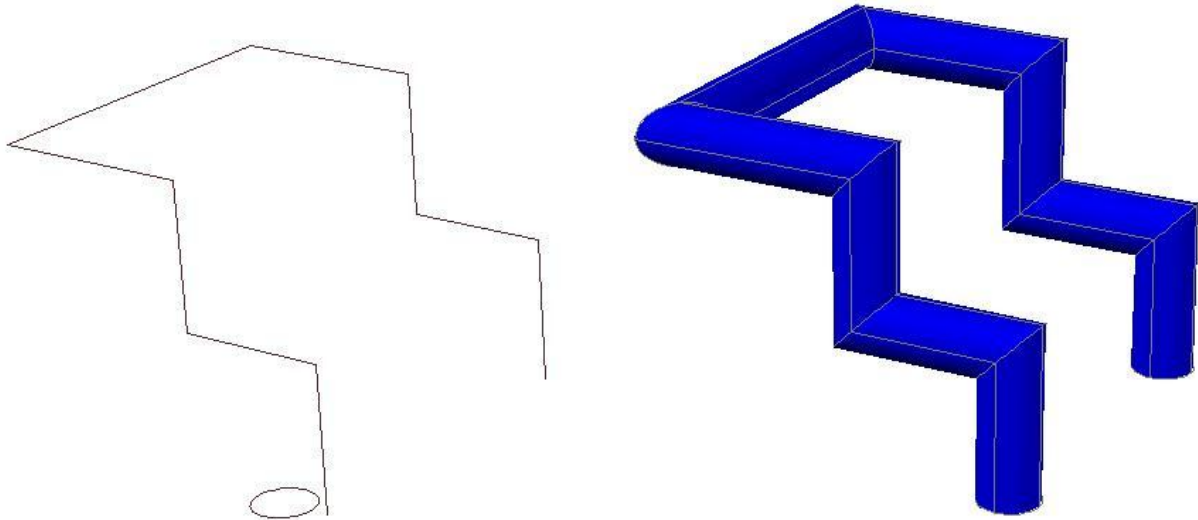



Figure 3-9

- An open profile produces a surface, and a closed object produces a solid. You can have more than one profile, but they must lie in the same plane

	Sweep
Ribbon :	Home tab> Modelling panel or <i>Solid</i> tab>Solid panel
Command prompt:	sweep

How to: Sweep Objects along a Path

1. Draw the profile object.
2. Draw the path on which to sweep the object.
3. Click  (Sweep).
4. Select the object(s) to be swept and press <Enter> to accept the selection set.
5. Select the path.

- AutoCAD displays an alert at the Command Line if the program cannot create the sweep.

Sweep Options

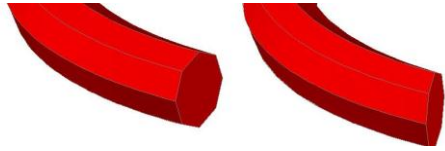
<p>Alignment</p>	<p>Aligns the object with the path before sweeping, as shown in Figure 3-10. The default is Yes. If you select No, it still allows you to create the sweep, but it is not aligned with the path.</p> <div style="text-align: center;">  <p><i>Aligned</i> <i>Not Aligned</i></p> <p>Figure 3-10</p> </div>
<p>Base Point</p>	<p>Changes the location of the base point of the sweep.</p>
<p>Scale</p>	<p>Changes the size of the profile as it moves along the path. For example, a scale of 0.5 shows the start profile at full size, but the end profile at half size. The size changes equally along the path.</p>
<p>Twist/ Bank</p>	<p>Specifies a twist angle or allows banking for a non-planer sweep path, such as a 3D polyline, 3D spline, or helix.</p>

- Objects that can be profiles are lines, arcs and elliptical arcs, circles and ellipses, open or closed 2D polylines and splines, planar (flat) 2D faces, 2D solids, traces, regions, planar surfaces, and faces of a solid.
- Objects that can be paths are arcs and elliptical arcs, circles and ellipses, open or closed 2D polylines and splines, 3D splines or polylines, helices, and edges of surfaces or solids
- To select faces of a solid for a profile or edges of surfaces or solids for paths, hold down the <Ctrl> key as you select them.

Modifying Sweeps

You can modify the profile and the path of a sweep using grips or with Properties, as shown in Figure 3-11. If the profile is aligned along the path, modify the profile in the path location.

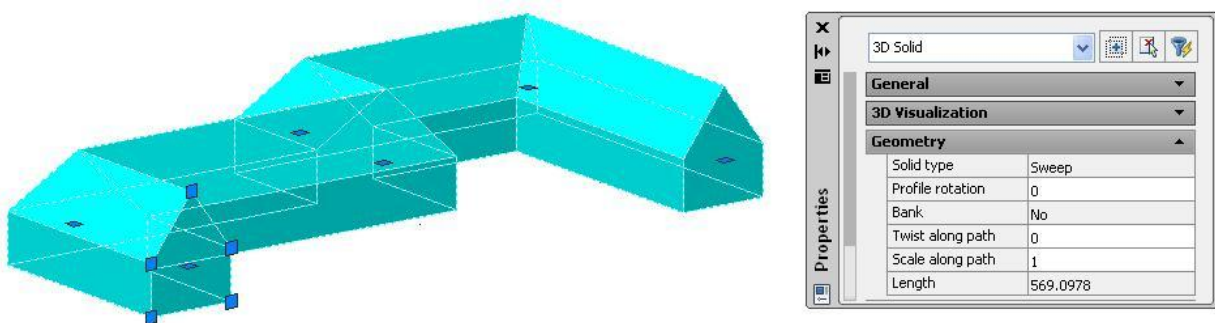

Figure 3-11

- Modifying the profile changes it along the full sweep path.
- **Polysolids** are a type of sweep. Therefore, their profiles and paths can also be modified.
- You can change the **Profile rotation**, **Twist along path**, and **Scale along path** options in Properties.

3D Paths

Several object types can be used as 3D paths, including **3D Polylines**, **Splines** and **Helixes**.

3D Polyline

When using the **Polyline** command, you are restricted to the current XY plane only. You can draw 2D polylines on various UCSs, but all points in the polyline must have the same Z-coordinate. A special command, **3D Polyline (3Dpoly)**, enables you to construct polylines using various X, Y, and Z coordinates for each point, as shown in Figure 3-12.

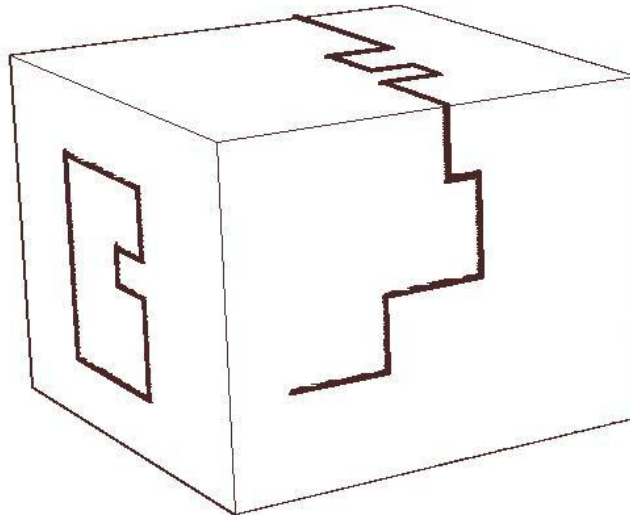

2D Polyline

3D Polyline

Figure 3-12

- A 3d Polyline is similar to regular polylines, except that it does not have an arc or width options. You can edit 3D Polylines with the **Polyline Edit (Pedit)** command.

	3D Polyline
Ribbon :	<i>Home tab>Draw Panel</i>
Command prompt:	3dpoly

- **Spline** object in AutoCAD can be drawn in 2D or 3D space. This means that points on the spline can have different Z-coordinates.

Helix

A helix is a complex 3D geometric object that spirals. It can be used as the basis of many different types of objects, such as the coils of a spring, a spiral staircase or screw threads, as shown in Figure 3-13.

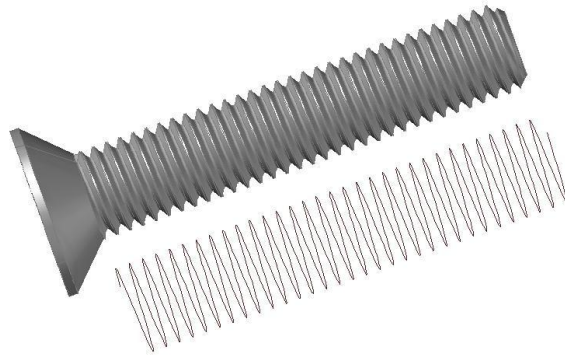



Figure 3-13

- The helix tool is not a solid or surface, but it can be used to create solids or surfaces.

	Helix
Ribbon :	<i>Home tab>Draw Panel (Expanded)</i>
Command prompt:	helix

How To: Create a Helix

1. Click  (Helix).
2. Specify a centre point for the base.
3. Specify a radius for the base or select the **Diameter** option to specify the diameter.
4. Specify a top radius or diameter. You see a 2D spiral if you move your cursor at this point.
5. Specify a height for the helix or select one of the options.

Helix Options

Turns	Sets the number of turns. You are prompted for the overall height. This selection modifies the Turn Height .
Twist	Sets the direction of the turn, either clockwise or anti-clockwise.
Turn Height	Specifies the distance between the turns. You are prompted for the overall height. This selection modifies the number of Turns .
Axis endpoint	Enables you to select a point for the top of the helix that could be at an angle from the original centre point.